

## DIRECT DETERMINATION OF ENTHALPIES OF VAPORIZATION OF LIQUID COMPOUNDS BY A MINIATURIZED EFFUSION CELL ADAPTED TO A COMMERCIAL MICROCALORIMETER

*G. Barone, G. Della Gatta\* and V. Elia*

DIPARTIMENTO DI CHIMICA, UNIVERSITÀ DI NAPOLI, VIA MEZZOCANNONE 4, 80134 NAPOLI, \* ISTITUTO DI CHIMICA GENERALE ED INORGANICA, FACOLTÀ DI FARMACIA, UNIVERSITÀ DI TORINO, VIA PIETRO GIURIA 9, 10125 TORINO, ITALY

A miniaturized effusion cell adapted to a Sorption LKB microcalorimeter has been designed, built and tested. Vaporization is performed isothermally into a vacuum through a small orifice permitting a vapour pressure very close to the equilibrium values. The cell has been tested by measuring the enthalpies of vaporization at 298.15 K of reference liquid compounds (water, benzene, propanol-1, propanol-2) with a reproducibility better than 1%. Enthalpies of vaporization of butanol-1 and deuterated water have also been determined.

Accurate knowledge of the enthalpies of vaporization of both liquid and solid compounds is of greatest importance in a wide spectrum of thermodynamic calculations, from enthalpies of formation [1] to enthalpies of solvation [2]. This accuracy is the more indispensable the weaker the interactions concerned are. In particular,  $\Delta_{\text{vap}}H$  values are employed to obtain enthalpies of solvation from solution heats at infinite dilution, allowing a closer description of the solute–solvent interactions [3, 4], as well as the possible partition of different contributions (e.g. solvent restructuring effect and hydrophobic interactions).

The additive character of the vaporization enthalpies has been proved but the correlations so far established [5–8] are restricted to liquid compounds of relatively small dimensions and simple molecular structure (e.g. with linear chain substituents). Direct and very precise determinations of vaporization enthalpies are thus increasingly required, particularly in connection with the more widespread employment of high-sensitivity microcalorimeters.

Several experimental techniques for the calorimetric determination of vaporization enthalpies for both liquid and solid compounds have been developed in the last twenty years [9–16]. Part are based on the measurement of the heat required to vaporize a well-known amount of substance into a vacuum under defined conditions as close as possible to the equilibrium values. These direct methods have proved useful, but their

applicability has shown to require a particularly suitable and fortunate combination of the parameters affecting first measurement and then accuracy.

Specifically, the sensitivity of the calorimetric devices and the rate of vaporization into a vacuum may greatly affect the amount of substance required for the experiments. Furthermore, the total mass (and/or form) of the cell in which the compound is weighed before measurement does not usually allow the employment of very low amounts of substance. On the other hand, vaporization at rates low enough to maintain acceptable equilibrium conditions produced very small heat effects, and calorimeters with very high sensibility were required. Lastly, the calorimetric apparatuses were, except in very few cases [12, 13, 16], "home-made" and thus of limited employment.

In this paper, an effusion cell adaptable to a commercial calorimeter is reported. It has been designed to meet the experimental requirements mentioned, while still allowing high-accuracy determinations.

## Experimental part

### *Description of the calorimetric cell*

The calorimetric cell (Fig. 1) has two parts: the effusion cell and the vacuum chamber. The effusion cell consists of a stainless steel cylinder closed by a disc of the same material with a central  $\phi = 100\text{--}300\ \mu\text{m}$  microhole. In the upper part of the cell, there are both a connection with the vacuum system (up to  $10^{-6}$  Torr) and a screw-plug moving a cylindrical shutter to put the effusion cell into contact with the vacuum chamber and produce evaporation. The external diameter of the cell is 8 mm and the height of the sample chamber 35 mm, the total height of the device being about 70 mm. Two Viton O-rings ensure vacuum-tightness, so that all the pumping power is concentrated on sample evaporation.

The vacuum system consists of a two-stage rotary vacuum pump connected to an oil diffusion pump. Between the cell and the vacuum system there is a liquid nitrogen trap to freeze the evaporated substance and prevent oil vapour from flowing back into the vacuum chamber.

### *Calorimetric apparatus*

The heat effect during vaporization has been measured with an LKB Sorption microcalorimeter based on thermal flux detection by thermopiles. The calibration was effected electrically and gave conversion factors reported in Table 1, the heater resistance being placed just under the cell cavity. The temperature was kept constant to  $\pm 0.02$  K. The signals from the thermal detectors were amplified by the internal LKB microvoltmeter (mod. 90001735) and recorded on a pendrive Servograph Radiometer (mod. REA 310).

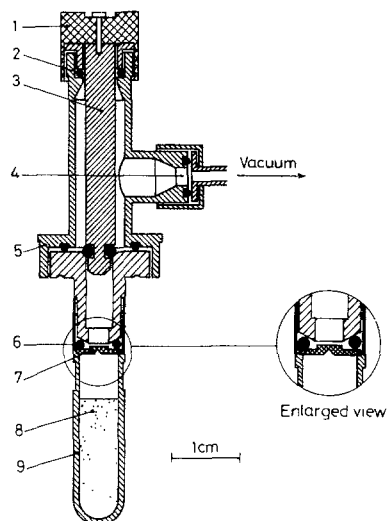

**Fig. 1** Calorimetric effusion cell (stainless steel) for measurement of vaporization heats in a Sorption LKB microcalorimeter (1 to 5: vacuum chamber, 6 to 9: sample chamber). 1. Screw-plug for starting and stopping vaporization, 2. O-ring ensuring tightness around the shutter cylinder, 3. cylindrical shutter, 4. connection to vacuum system ( $P \approx 10^{-6}$  Torr), 5. level at which the shutter acts, 6. O-ring ensuring tightness of the sample chamber, 7. metal disc with central microhole, 8. sample (liquid), 9. part of the cell in contact with thermal detectors

**Table 1** Conversion factors obtained by electrical calibration<sup>a</sup>

Record. sens., mV mm <sup>-1</sup>	Measur., No.	Conversion factor, W mm <sup>-1</sup>	$\delta$ , %
5	4	$7.68 \pm 0.041^b \times 10^{-5}$	0.53
10	4	$1.54 \pm 0.009^b \times 10^{-4}$	0.58
20	6	$3.10 \pm 0.025^b \times 10^{-4}$	0.81
50	6	$7.79 \pm 0.036^b \times 10^{-4}$	0.46

<sup>a</sup> at constant amplification ( $\times 10^3$ ) of the calorimetric signal, *b*, mean average deviation,  $\delta$ .

### Experimental procedure

The cell is filled with about 250 mm<sup>3</sup> of substance, and after positioning the disc is closed. Before measurements are taken, the cell and its contents are degassed outside the calorimeter to prevent the downstream effect of air in the vapour and the liquid sample. The cell is closed and weighed on a high precision balance ( $\pm 0.1$  mg), the total weight being less than 50 g. At the end of the vaporization experiments it is again weighed to obtain the amount of substance vaporized. Particular care must be taken

to clean the outer part of the cell, which comes into contact with the oil used to wet the calorimeter cavity and ensure a good thermal contact with the detectors. The cleaning procedure has been standardized. After each experiment, the cell was carefully cleaned with blotting-paper wetted with benzene, then it was immersed in 50 ml of the same solvent for 5 minutes, and finally dried with a clean blotting-paper prior to exposure to a filtered cool air current (5 minutes). This procedure gave a weighing precision of  $\pm 0.25$  mg.

The cell is then inserted in the calorimeter cavity and connected to the vacuum line. Attainment of the thermal equilibrium is revealed by a well-stabilized and constant calorimetric base-line (30–60 minutes), the temperature being kept constant at 298.15 K. The external knob is turned to open the shutter and start the vaporization process. A deviation is thus produced in the calorimetric signal. Its constancy is proof of a steady vaporization rate (Fig. 2).

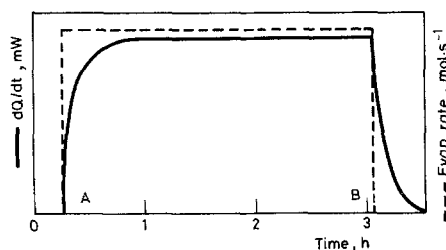

Fig. 2 Typical vaporization curve (full line), without thermal perturbations at the opening (A) and closing (B) of the effusion cell. Vaporization rate variation is also reported (dashed line)

With this experimental apparatus the heat related to the vaporization of weighed amounts of substance can be calculated in two different ways.

i) Heat of vaporization is deduced from the area of the curves obtained by evaporation. In this method, precision is low because of the two transient stages corresponding to the opening and closing of the effusion cell. Both operations are affected by exothermic effect due to friction. The former also includes endothermic phenomena (expansion of the vapour phase, downstream effects). Such interfering effects may appreciably affect the determination of the area. Sabbah et al. [13] adopted this method successfully by the introduction of a correction term derived from blank assays. This was probably due to a sufficiently good reproducibility of the interfering effects.

(ii) Heat of vaporization is computed from the thermal flux in the steady-state interval of the evaporation process, and from the relevant vaporization rates. The advantage of miniaturizing the cell and related parts (shutter, connections) is evident, in that it allows the use of a high precision analytical balance. As the liquid substance evaporates at a constant rate, the calorimetric deviation is parallel to the base-line over a wide interval (Fig. 2). The process can be stopped at different steps and the evaporated amounts determined. The influence of transient stages is avoided, because

vaporization heat is obtained only from the power of the thermal effect (deviation of the calorimetric base-line) and the time of vaporization relevant to a given amount of substance. The base-line deviation is measured with an uncertainty of  $\pm 0.5$  mm. Thus, for deviations higher than 100 mm, as usually observed in this work, the precision is better than  $\pm 0.5\%$ . The vaporization time is computed between the opening and closing of the effusion cell with a fairly satisfactory accuracy in view of the length of the process (1/2–2 hours).

### Materials

Water, benzene, propanol-1, propanol-2 were used as reference compounds. The heats of vaporization of  $D_2O$  and butanol-1 were also determined. Water was a deionized and tridistilled product. Benzene and butanol-1 were Merck pure reagents for spectroscopy (99.7%). Benzene was carefully dried by refluxing on Na, then distilled and maintained in a nitrogen dry atmosphere. The two propanols were Fluka spectroscopy grade reagents (99.5 and 99.9% by volume, respectively). The  $D_2O$  was a Fluka product (99.7%): the vials were opened, just before filling the cell, in a dry box. Moreover all these substances were submitted to prolonged degassing directly inside the calorimetric cell.

### Thermodynamic considerations

The molar enthalpy change ( $\Delta_{\text{vap}}H$ ) on vaporization at equilibrium conditions is

$$\Delta_{\text{vap}}H = \Delta_{\text{vap}}U + P_{\text{sat}}(V^g - V^l) \quad (1)$$

where  $\Delta_{\text{vap}}U$  is the molar internal energy change,  $V^g$  and  $V^l$  are the molar volumes of the vapour and liquid phases respectively, and  $P_{\text{sat}}$  is the saturated vapour pressure at the experimental temperature. The term  $P_{\text{sat}}(V^g - V^l)$  represents the pressure-volume work exerted during vaporization by the evaporating molecules against the saturation pressure. When the experimental pressure ( $P_{\text{exp}}$ ) is lower than  $P_{\text{sat}}$ , the experimental molar vaporization enthalpy is given by

$$\Delta_{\text{vap}}H^{\text{exp}} = \Delta_{\text{vap}}U^{\text{exp}} + P_{\text{exp}}(V^g - V^l) \quad (2)$$

where

$$\Delta_{\text{vap}}U^{\text{exp}} = \Delta_{\text{vap}}U + \int_{P_{\text{sat}}}^{P_{\text{exp}}} \left[ \frac{dU}{dP} \right]_{T_{\text{exp}}} dP \quad (3)$$

Assuming an ideal behaviour for the vapour phase  $\Delta_{\text{vap}}U^{\text{exp}} = \Delta_{\text{vap}}U$ , as the integral term is zero

$$\Delta_{\text{vap}}H^{\text{exp}} = \Delta_{\text{vap}}U + P_{\text{exp}}(V^g - V^l) \quad (4)$$

Neglecting  $V^l$ , as compared with  $V^g$ , the difference between the equilibrium data (1) and those obtained under experimental conditions (4), is solely due to the difference in the pressure-volume work of the evaporating liquid.

$$\delta\Delta_{\text{vap}}H = \Delta_{\text{vap}}H - \Delta_{\text{vap}}H^{\text{exp}} = RT_{\text{exp}} \left[ 1 - \frac{P_{\text{exp}}}{P_{\text{sat}}} \right] \quad (5)$$

#### *Possible sources of errors*

As a consequence of (5),  $\delta\Delta_{\text{vap}}H$  may vary from zero ( $P_{\text{exp}} = P_{\text{sat}}$ ) to  $RT(P_{\text{exp}} = 0)$ , so that the maximum value of error due to the non-equilibrium conditions is, at 298.15 K, about 2.5 kJ mol<sup>-1</sup>. This is a substantial fraction of the vaporization enthalpy of the lowest molecular weight organic compounds. The factors governing the mass flow on vaporization have been exhaustively discussed by Morawetz [11]. The pressure in the interior of the effusion cell is given by the following relationship [17]

$$P_{\text{exp}} = \frac{\alpha}{\alpha + a/A} P_{\text{sat}}$$

where  $a$  and  $A$  are the section area of the orifice and the evaporation surface of the compound respectively, and  $\alpha$  the evaporation coefficient. According to [13], we can assume that for  $a/A$  ratios less than  $10^{-2}$ , the  $P_{\text{exp}}$  can be regarded as very close to the equilibrium values. In the present work, the micro-orifice dimensions were chosen for each compound to minimize this ratio to about  $10^{-3}$ , and approach equilibrium conditions. Rates of evaporation were around  $5 \times 10^{-7}$  mol s<sup>-1</sup>, equal to evaporation of about  $5 \times 10^2$  molecular layers per second. It is evident that these experimental conditions require the use of a high sensitivity microcalorimeter.

Incomplete heat exchange between the evaporating substance and the calorimetric detectors due to a possibly still too high effusion rate is a second source of errors. Inside the cell heat is conducted through both the liquid and the vapour phases. Liquid conduction can be considered kinetically complete, as the recorded signal is only dependent on the efficiency of the calorimeter cavity and the sensitivity of the thermoelectric detectors. By contrast, vapour conduction may be affected by a possible loss of heat due to incomplete heat exchange between evaporating molecules and the calorimetric cell varying with effusion rates and the compounds examined. By plotting  $\Delta_{\text{vap}}H$  vs. molar flow rates, the experimental results can be extrapolated to zero rate, to obtain corrected vaporization enthalpy values. The results reported in this work did not need such a correction. Further possibilities of errors dependent on the accuracy of the determination of the evaporated amounts and the relevant heat from the thermograms have already been discussed in the experimental part.

### Test experiments

The results of measurements at 298.15 K on very high purity water, benzene, propanol-1, propanol-2, butanol-1, deuterated water are shown in Tables 2 to 7. Column 1 gives the amount of evaporated substance,  $\Delta m$ , mg, column 2 the diameter of the effusion orifice,  $\varphi_{or}$ , mm, column 3 the rate of evaporation,  $V_{vap}$ , mol s<sup>-1</sup>, column 4 the thermal flux,  $dQ/dt$ , mW, and column 5 the vaporization enthalpy,  $\Delta_{vap}H$ , kJ mol<sup>-1</sup>. Slight discrepancies in vaporization rates with orifices of same dimensions must be ascribed to different vacuum conditions. The last column contains the deviation from the mean value. The computed mean value of  $\Delta_{vap}H$ , with its mean average deviation and percent value are set out below each table. Quoted literature data are also reported for comparison. The heat of vaporization of butanol-1 is slightly more uncertain (reproducibility about 2%) than those for other substances, even though the mean value is in very close agreement with more recent data.

**Table 2** Enthalpy of vaporization of water at 298.15 K

$\Delta m$ , mg	$\varphi_{or}$ , mm	$V_{vap}$ , mol s <sup>-1</sup>	$dQ/dt$ , mW	$\Delta_{vap}H$ , kJ mol <sup>-1</sup>	$\Delta$
31.1	0.10	$1.081 \times 10^{-6}$	47.1	43.57	-0.19
196.1	0.10	1.296	56.7	43.75	-0.01
154.2	0.12	2.038	89.3	43.82	+0.06
201.6	0.12	2.050	90.0	43.90	+0.14

Conversion factor,  $7.79 \pm 0.036 \times 10^{-4}$  W mm<sup>-1</sup>.  $\Delta_{vap}H = 43.76 \pm 0.10$  kJ mol<sup>-1</sup>. Percent mean deviation  $\pm 0.23\%$ . Reference data: 43.99 [19]; 43.991 [20]; 43.84 [13]; 43.98 [21]; 44.02 [22]; 43.99 [23]; 43.98 [24]; 44.02, 43.05, 43.93, 44.06 [11]; 44.04 [25]; 44.01 [27].

**Table 3** Enthalpy of vaporization of benzene at 298.15 K

$\Delta m$ , mg	$\varphi_{or}$ , mm	$V_{vap}$ , mol s <sup>-1</sup>	$dQ/dt$ , mW	$\Delta_{vap}H$ , kJ mol <sup>-1</sup>	$\Delta$
679.2	0.10	$3.501 \times 10^{-6}$	120	34.27	-0.04
688.4	0.12	4.677	162	36.64	+0.33
685.6	0.14	5.114	174	34.02	-0.29

Conversion factor,  $7.79 \pm 0.036 \times 10^{-4}$  W mm<sup>-1</sup>.  $\Delta_{vap}H = 34.31 \pm 0.22$  kJ mol<sup>-1</sup>. Percent mean deviation  $\pm 0.64\%$ . Reference data: 33.87 [24]; 33.84 [26]; 33.87 [28]; 33.85 [20]; 33.90 [25]; 33.79 [14], [29].

**Table 4** Enthalpy of vaporization of propanol-1 at 298.15 K

$\Delta m$ , mg	$\varphi_{or}$ , mm	$V_{vap}$ , mol s <sup>-1</sup>	dQ/dt, mW	$\Delta_{vap}H$ , kJ mol <sup>-1</sup>	$\Delta$
299.8	0.10	$7.259 \times 10^{-7}$	34.4	47.40	-0.18
449.8	0.10	7.651	37.1	48.50	+0.91
628.6	0.10	7.712	36.6	47.46	-0.12
630.5	0.10	7.194	33.8	46.98	+0.40

Conversion factor,  $3.10 \pm 0.025 \times 10^{-4}$  W mm<sup>-1</sup>.  $\Delta_{vap}H = 47.58 \pm 0.40$  kJ mol<sup>-1</sup>. Percent mean deviation  $\pm 0.84\%$ . Reference data: 47.37 [24]; 47.49 [21]; 47.32 [5]; 47.28 [30]; 47.51 [31]; 47.53 [32].

**Table 5** Enthalpy of vaporization of propanol-2 at 298.15 K

$\Delta m$ , mg	$\varphi_{or}$ , mm	$V_{vap}$ , mol s <sup>-1</sup>	dQ/dt, mW	$\Delta_{vap}H$ , kJ mol <sup>-1</sup>	$\Delta$
433.8	0.10	$1.002 \times 10^{-6}$	45.8	45.70	+0.18
544.5	0.10	1.006	45.8	45.53	+0.01
560.2	0.10	1.015	46.0	45.32	-0.20

Conversion factor,  $3.10 \pm 0.025 \times 10^{-4}$  W mm<sup>-1</sup>.  $\Delta_{vap}H = 45.52 \pm 0.13$  kJ mol<sup>-1</sup>. Percent mean deviation  $\pm 0.28\%$ . Reference data: 45.34 [21]; 45.23 [5]; 44.02 [30]; 45.52 [34]; 45.56 [35].

**Table 6** Enthalpy of vaporization of butanol-1 at 298.15 K

$\Delta m$ , mg	$\varphi_{or}$ , mm	$V_{vap}$ , mol s <sup>-1</sup>	dQ/dt, mW	$\Delta_{vap}H$ , kJ mol <sup>-1</sup>	$\Delta$
93.6	0.10	$1.374 \times 10^{-7}$	7.15	52.04	-0.21
230.2	0.10	1.058	5.58	52.74	+0.49
266.8	0.10	1.374	7.05	51.31	-0.94
482.9	0.10	1.840	9.43	51.25	-1.00
532.6	0.10	1.370	7.39	53.94	+1.69

Conversion factor,  $7.68 \pm 0.041 \times 10^{-5}$  W mm<sup>-1</sup>.  $\Delta_{vap}H = 52.25 \pm 0.86$  kJ mol<sup>-1</sup>. Percent mean deviation  $\pm 1.64\%$ . Reference data: 52.34 [21]; 52.30 [22]; 51.00 [30]; 52.80 [32]; 52.68 [33].

**Table 7** Enthalpy of vaporization of deuterated water at 298.15 K

$\Delta m$ , mg	$\varphi_{or}$ , mm	$V_{vap}$ , mol s <sup>-1</sup>	dQ/dt, mW	$\Delta_{vap}H$ , kJ mol <sup>-1</sup>
157.3	0.10	$0.879 \times 10^{-6}$	39.9	45.39
215.0	0.10	1.054	48.2	45.73

Conversion factor,  $3.10 \pm 0.025 \times 10^{-4}$  W mm<sup>-1</sup>.  $\Delta_{vap}H = 45.56 \pm 0.17$  kJ mol<sup>-1</sup>. Percent mean deviation  $\pm 0.37\%$ .



The value found for  $D_2O$  ( $45.51 \pm 0.19 \text{ kJ mol}^{-1}$ , Table 7) is of interest with regard to the relative intensity (strength and extension) of the intermolecular interactions in normal and heavy water. By comparison with the known value of  $\Delta_{\text{vap}}H$  at the normal boiling point,  $41.534 \text{ kJ mol}^{-1}$  at  $374.59 \text{ K}$  (18),  $\Delta C_p$  (in the range of temperatures considered) should be approximately  $-52.0 \text{ J mol}^{-1} \text{ K}^{-1}$ . The corresponding value for water is  $-41.928 \text{ J mol}^{-1} \text{ K}^{-1}$  at normal boiling temperature, indicating a possible lower degree of "structuration".

\* \* \*

The work was partially supported by the financial aid of the Italian Consiglio Nazionale delle Ricerche. The authors wish to thank Dr. R. Sabbah of the CNRS, Marseille, for his helpful suggestions.

## References

- 1 P. Sellers, G. Stridh and S. Sunner, *J. Chem. Eng. Data*, **23** (1978) 250.
- 2 C. V. Krishnan and H. L. Friedman, *Solute-Solvent Interactions Vol. 2, Chapt. 9* (J. F. Coetzee and C. D. Ritchie, eds.), M. Dekker Inc., New York, 1976.
- 3 C. V. Krishnan and H. L. Friedman, *J. Phys. Chem.*, **73** (1969) 3934 and **23** (1971) 3598.
- 4 P. P. S. Saluja, L. A. Peacock and R. Fuchs, *J. Am. Chem. Soc.*, **101** (1979) 1958.
- 5 I. Wadsö, *Acta Chem. Scand.*, **20** (1966) 544.
- 6 I. Wadsö, *Acta Chem. Scand.*, **22** (1968) 2438.
- 7 E. F. Meyer and K. S. Stec, *J. Am. Chem. Soc.*, **93** (1971) 5451.
- 8 M. Manson, P. Sellers, G. Stridh and S. Sunner, *J. Chem. Thermodynamics*, **9** (1977) 91.
- 9 I. Wadsö, *Acta Chem. Scand.*, **14** (1960) 566 and **20** (1966) 536.
- 10 E. Morawetz and S. Sunner, *Acta Chem. Scand.*, **17** (1963) 473.
- 11 E. Morawetz, *Acta Chem. Scand.*, **22** (1968) 1509 and *Chem. Scripta*, **1** (1971) 103.
- 12 L. Malaspina, R. Gigli and G. Bardi, *J. Chem. Thermodynamics*, **3** (1971) 827 and *J. Chem. Phys.*, **59** (1973) 387.
- 13 R. Sabbah, R. Chastel and M. Laffitte, *Thermochim. Acta*, **5** (1972) 117.
- 14 V. Svoboda, V. Hynek, F. Veselý and J. Pick, *Collection Czech. Chem. Comm.*, **37** (1972) 3165.
- 15 S. Sunner and C. Svensson, *J. Chem. Soc. Faraday Trans. 1.*, **75** (1979) 2359.
- 16 G. Della Gatta, L. Stradella and P. Venturello, *J. Solution Chem.*, **10** (1981) 209.
- 17 J. L. Margrave, *Physicochemical Measurements at High Temperatures*. (J. O. M. Brockris, J. L. White and J. D. Mackenzie, eds.), Butterworths, London, 1959, p. 232.
- 18 A. I. Shatenshtein, E. A. Yakovleva, E. N. Zvyaginsteva, Ya. M. Vanshavsii, E. I. Israilevich and N. M. Dyklino, *Isotopic Water Analysis*, 2nd Ed., U. S. Atomic Energy Comm. Transl., AEC-tr-4136, 1960.
- 19 F. D. Rossini, D. D. Wagman, W. H. Evans, S. Levine and J. Jaffe, *Selected Values of Chemical Thermodynamics Properties*, Circ. NBS 500, U. S. Gov. Printing Office, Washington D. C., 1952.
- 20 *Handbook of vapor pressures and heats of vaporization of hydrocarbons and related compounds*, (B. J. Zwolinski and R. C. Wilhoit eds.), API Res. Project 44, Thermodynamic Research Center, Texas A & M Univ., 1971.
- 21 J. Polak and G. C. Benson, *J. Chem. Thermodynamics*, **3** (1971) 235.
- 22 I. Wadsö, *Acta Chem. Scand.*, **20** (1966) 536.

- 23 N. S. Osborne, H. F. Stimson and D. C. Ginnings, *J. Res. Nat. Bur. Stand.*, A 23 (1939) 261.
- 24 V. Majer, V. Svoboda, V. Hynek and J. Pick, *Collection Czech. Chem. Comm.*, 43 (1978) 1313.
- 25 J. Konicek, *Acta Chem. Scand.*, 27 (1973) 1496.
- 26 S. S. Todd, I. A. Hossenlopp and D. W. Scott, *J. Chem. Thermodynamics*, 10 (1978) 641.
- 27 D. D. Wagman, J. E. Kilpatrick, W. J. Taylor, K. S. Pitzer and F. D. Rossini, *J. Res. Nat. Bur. Stand.*, A 34 (1945) 143.
- 28 N. S. Osborne and D. C. Ginnings, *J. Res. Nat. Bur. Stand.*, A 39 (1947) 453.
- 29 V. Svoboda, F. Veselý, R. Holub and J. Pick, *Collection Chem. Czech. Comm.*, 38 (1973) 3539.
- 30 K. G. McCurdy and K. J. Laidler, *Can. J. Chem.*, 41 (1963) 1867.
- 31 J. F. Matthews and J. J. McKetta, *J. Phys. Chem.*, 65 (1961) 758.
- 32 J. H. S. Green, *J. Appl. Chem.*, 11 (1961) 397.
- 33 J. F. Counsell, J. L. Hales and J. F. Martin, *Trans. Faraday Soc.*, 61 (1965) 1869.
- 34 J. L. Hales, J. D. Cox and E. R. Lees, *Trans. Faraday Soc.*, 59 (1963) 1544.
- 35 N. S. Berman, C. W. Larkam and J. J. McKetta, *J. Chem. Eng. Data*, 9 (1964) 218.

**Zusammenfassung** — Es wurde eine miniaturisierte Effusionszelle für das Sorption LKB-Mikrokalorimeter entworfen, gebaut und getestet. Die Verdampfung erfolgt in ein Vakuum durch eine kleine Öffnung, wodurch ein dem Gleichgewichtswert nahekommender Dampfdruck gewährleistet ist. Die Zelle wurde durch Messung der Verdampfungsenthalpien von flüssigen Referenzverbindungen (Wasser, Benzol, Propanol-1, Propanol-2) bei 298.15 K getestet, wobei die Reproduzierbarkeit besser als 1% war. Verdampfungsenthalpien von Butanol-1 und deuteriertem Wasser wurden ebenfalls bestimmt.

**Резюме** — Собрана и испытана малогабаритная ячейка истечения, адаптированная к сорбционному ЛКБ микрокалориметру. Испарение было проведено изотермически в вакууме через небольшое отверстие, что позволило получить давление паров, близкое к равновесному. Ячейка была испытана для измерения энтальпий испарения при 298.15 К стандартных жидких соединений—вода, бензол, пропанол-1 и пропанол-2—с воспроизводимостью, лучше 1%. Определены также энтальпии испарения бутанола-1 и тяжелой воды.

The AICAT material is finished.